



**Stainless Steel
95C34 Series**

**Toilet Partition Installation
Manual**

PHONE: 866-820-3579

FAX: 866-317-2786

ATTENTION

DO NOT MIX
FASTENER PACKS

**EACH FASTENER PACK HAS THE NECESSARY
BOLTS, BARRELS AND SCREWS TO INSTALL
THE RESPECTIVE PANEL, PILASTER OR DOOR.**











**TORX HEAD BITS ARE PACKED IN THE EXTRA
FASTENER PACKS.**

TABLE OF CONTENTS

<u>STEP</u>		<u>PAGE</u>
1	TOOLS REQUIRED	4
2	GETTING STARTED	5
3	MARK THE PARTITION LAYOUT	6
4	INSTALL THE PANELS	8
5	INSTALL THE WALL PILASTER.....	10
6	INSTALL THE PILASTERS.....	12
7	INSTALL THE HEADRAIL.....	14
8	ATTACH THE DOORS	15
9	ATTACH THE DOOR HARDWARE	18
10	BOLT AND BARREL SIZES.....	20

1 TOOLS REQUIRED

- TAPE MEASURE
- 4 FOOT LEVEL
- RATCHET TYPE BIT DRIVER (torx head bits supplied)
- FLAT HEAD SCREWDRIVER
- PHILLIPS HEAD SCREWDRIVER
- 1 WAY SCREWDRIVER
- TWO 9/16" OPEN END WRENCHES
- HAMMER
- TWO 12" BLOCKS
- DRILL
- ROTARY HAMMER DRILL
- HACKSAW
- 5/16" CARBIDE TIPPED HAMMER DRILL BIT
- 5/8" CARBIDE TIPPED HAMMER DRILL BIT
- 1/4" HIGH SPEED STEEL DRILL BITS
- CHALK BOX

FA-102	15/16" BOLT	
FA-103	1-1/16" BOLT	
FA-104	1-3/16" BOLT	
FA-110	1-1/2" BOLT	
FA-201	5/8" BARREL	
FA-305	3/4" SCREW	
FA-307	3/4" SCREW	
FA-306	5/8" SCREW	
FA-802	1" SCREW	
FA-300	1-1/2" SCREW	
FA-400	PLASTIC ANCHOR	
FIGURE 1.1 FASTENER DETAIL		

2 GETTING STARTED

- 2.1 Find the packing list in the box marked “Packing List”
- 2.2 Check delivered materials and make sure no parts are damaged or missing.
- 2.3 Check dimensions in each bathroom against the shop drawings marked “For Field Use”. Make notes of differences.
- 2.4 Clear bathrooms to provide workroom.

Thank you for choosing partitions from National Toilet Partitions. We appreciate your business. At Partition Systems, we strive to provide the industry’s best partitions with comprehensive installation guides.

If you need assistance, have questions or comments; contact our customer service department at:

Customer Service
National Toilet Partitions

(866) 820-3579, Fax: (866) 317-2786

3 MARK THE PARTITION LAYOUT

- 3.1 Establish and mark the center of the panels across the back wall according to shop drawings. For end-panels and alcove-panels mark the outer edge. (See fig.3.1)
- 3.2 Establish and mark the panel-brackets on the back wall 18" and 64" from the finished floor.
- 3.3 Establish and mark the wall-pilaster location on the side wall according to shop drawings. (See fig.3.1)
- 3.4 Establish and mark the pilaster-brackets on the side wall 18" and 64" from the finished floor.
- 3.5 Establish and mark the outer edges of each pilaster from the back and side walls according to shop drawings. (See fig.3.1)
- 3.6 Mark and drill holes for the floor fasteners.
 - 3.6.1 For standard leveling device place the shoe on the floor centered between the outer edges of the pilaster. Using the shoe as a template, mark the holes. Drill a 2" deep hole in the floor with a 5/16" bit. (See fig.5-B.2)
- 3.7 Mark wall bracket mounting holes using the brackets as a template. Center and level the brackets before marking (See fig.3.1). For end-panels and alcove-panels use the outer edge.
- 3.8 Drill 5/16" holes for wall brackets.
- 3.9 Insert plastic anchors (FA-400) into holes.
- 3.10 Secure wall and pilaster brackets with 1½" screws (FA-300). (See fig.3.2)

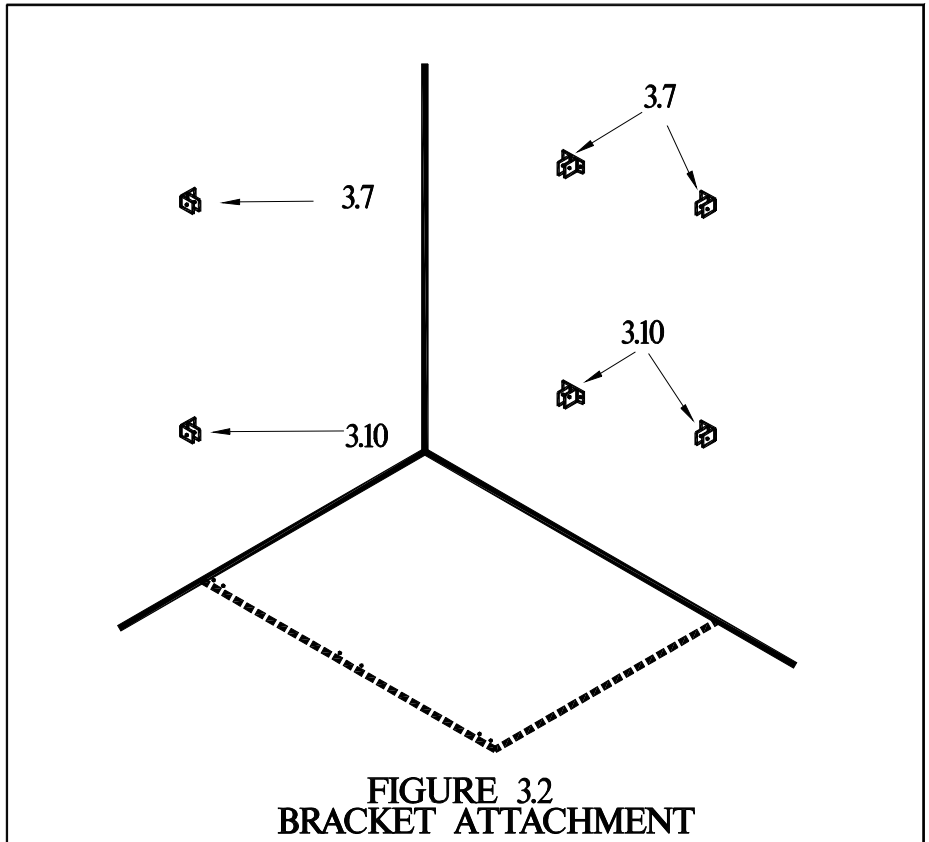
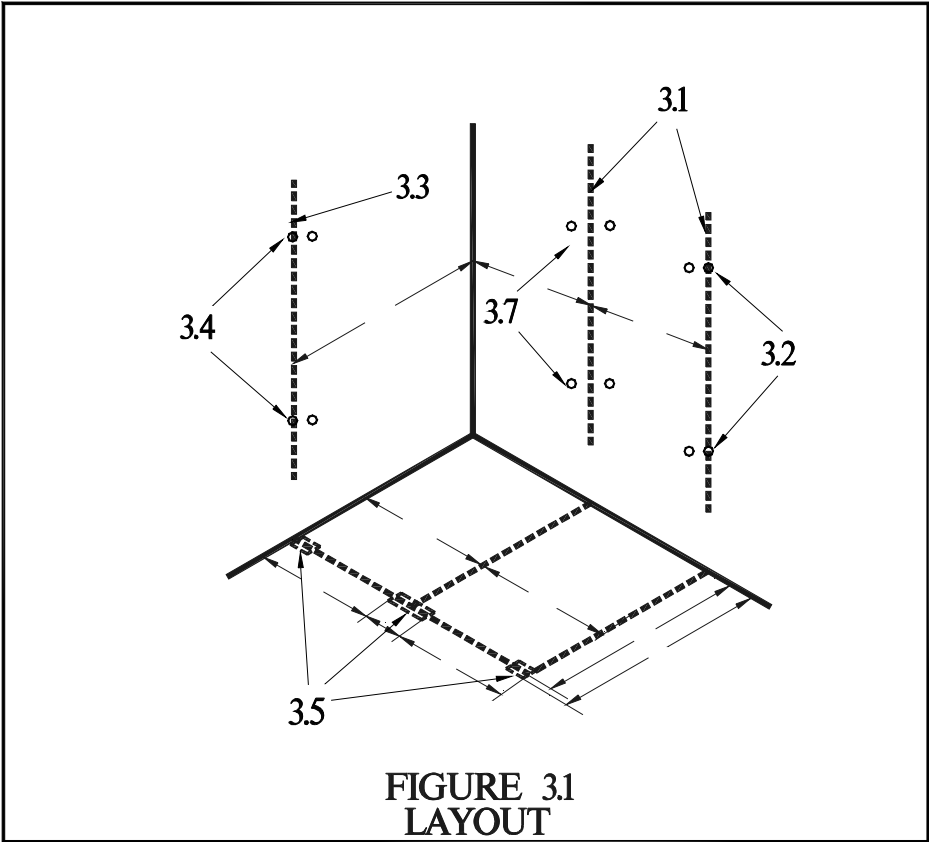

4 INSTALL THE PANELS

- 4.1 Place a 12" high support in position to hold up the panels.
(see fig. 4.1)
- 4.2 Set the panel on the support and slide the panel into the wall brackets until the bottom is $\frac{1}{2}$ " from the wall.
- 4.3 Drill the bottom bracket hole through the panel with a $\frac{1}{4}$ " drill bit and secure with a $\frac{15}{16}$ " bolt (FA-201) and a $\frac{5}{8}$ " barrel (FA-201).
- 4.4 Level the top of panel.
- 4.5 Drill the top bracket hole with a $\frac{1}{4}$ " drill bit and secure with a $\frac{15}{16}$ " bolt (FA-201) and a $\frac{5}{8}$ " barrel (FA-201).
- 4.6 Repeat steps 4.1 through 4.5 for each panel.

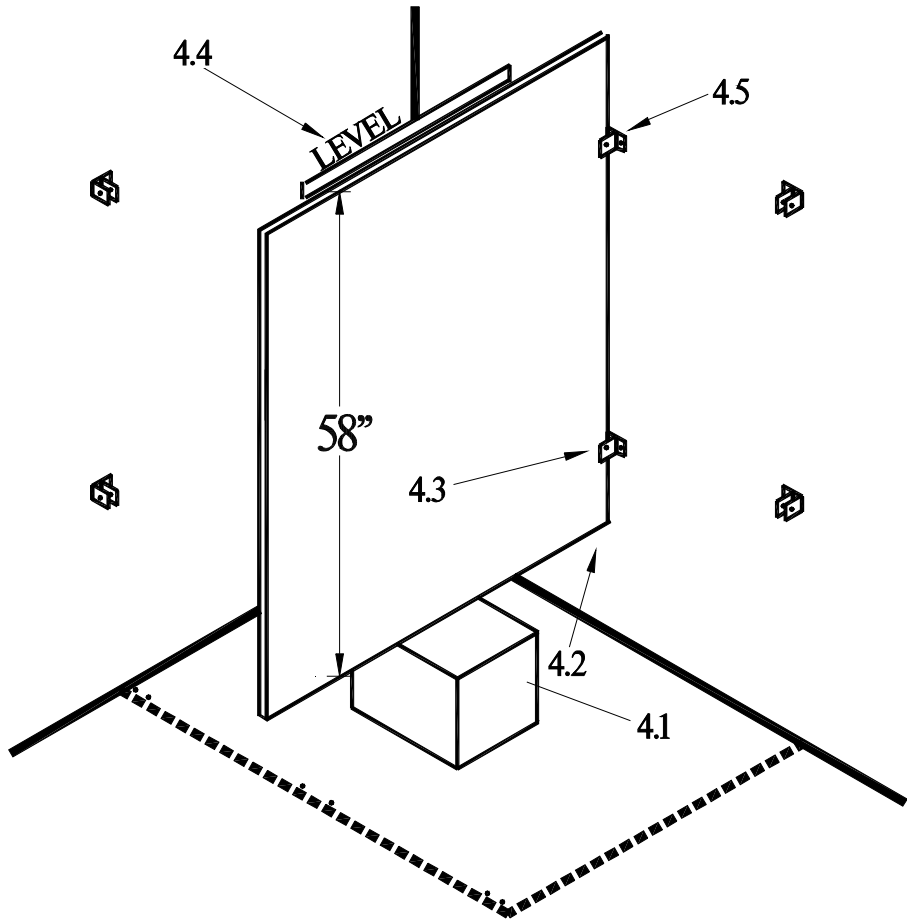
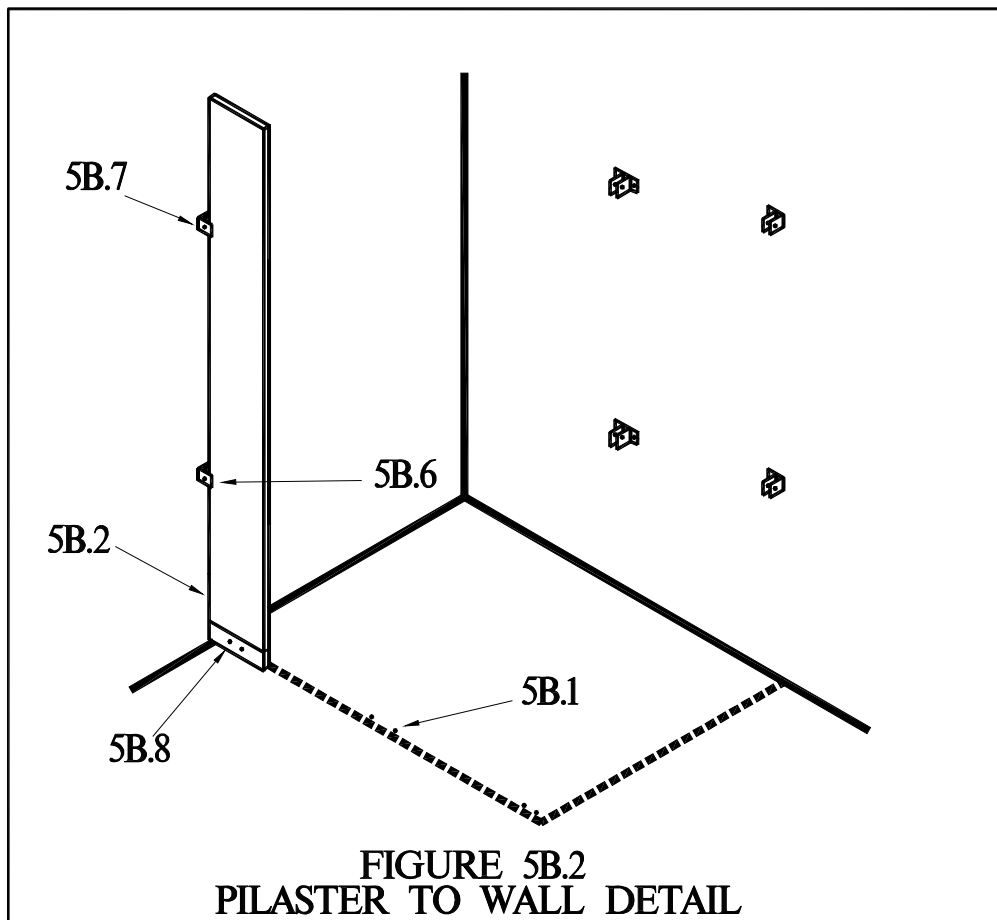
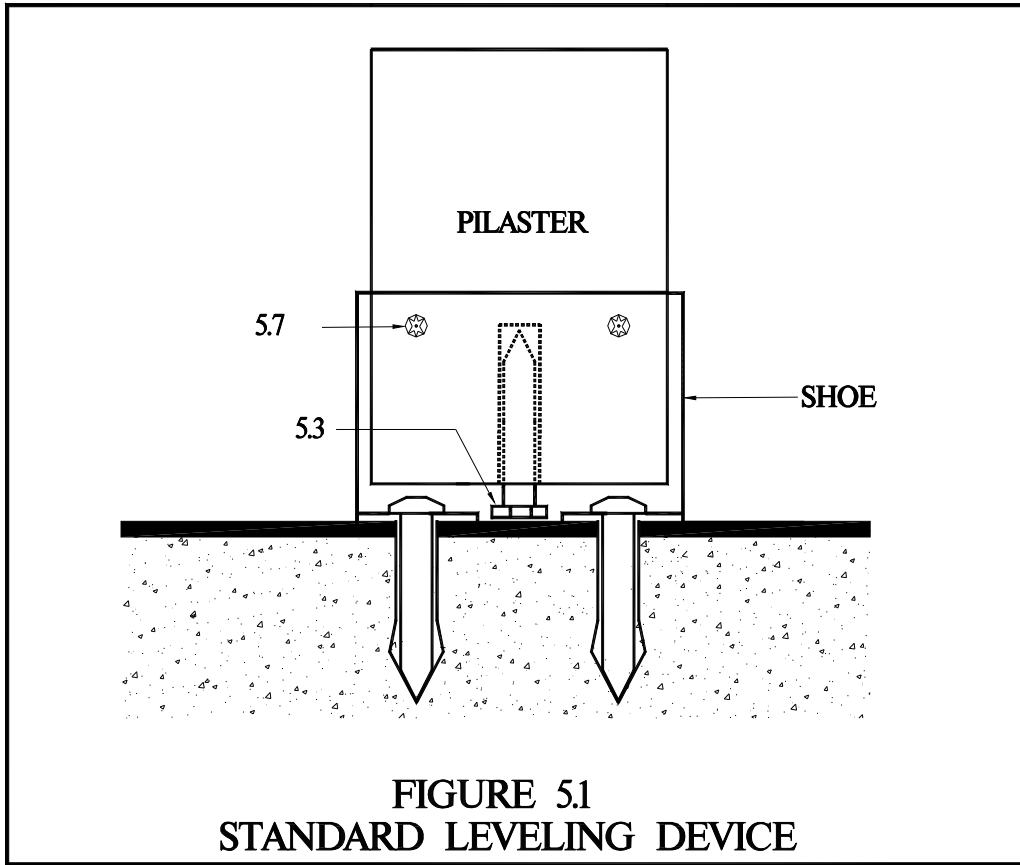

FIGURE 4.1
PANEL INSTALLATION

5 INSTALL THE WALL PILASTER

- 5.1 Mount the shoe/heel to the floor with 2" stainless steel screws (FA-808)
- 5.2 Place the pilaster into the shoe and slide the wall-pilaster into the wall brackets. (See figure 5B.2)
- 5.3 Using the Leveling Bolt in the bottom of the pilaster raise (lower) the pilaster.
- 5.4 Place the pilaster into the shoe and slide the wall-pilaster into the wall brackets.
- 5.5 Drill the bottom bracket hole through the pilaster with a 1/4" drill bit. Secure with a 1-3/16" bolt (FA-104) and a 5/8" barrel. (FA-201)
- 5.6 Check level and drill the top hole through the pilaster with a 1/4" drill bit. Secure with a 1-3/16" bolt (FA-104) and a 5/8" barrel. (FA-201)
- 5.7 Drill 3/16" into not through the shoe and pilaster. Secure with a 5/8" screw (FA-306).



6 INSTALL THE PILASTERS

- 6.1 Prepare the pilaster floor fasteners. For leveling device follow steps 5A.1 through 5A.3. For shoe & heel follow step 5B.1.
- 6.2 Place the pilaster onto the leveling device (or heel) and level the top of the pilaster with the pilaster at the wall.
- 6.3 On the back of the pilaster mark the center of the panel according to shop drawings. (See fig 6.2)
- 6.4 Mark the pilaster where the brackets will be located at 18" and 64" off the floor for shoe and heel, 17" and 63" for leveling device.
- 6.5 Place the pilaster-to-panel brackets onto the pilaster where the marks are made. Mark the mounting holes. (see fig 6.2)
- 6.6 Drill 3/16" holes, into not through the pilaster and secure the pilaster-to-panel brackets with 5/8" screws (FA-306).
- 6.7 Place the pilaster into the shoe. Slide the panel into the bracket.
- 6.8 Secure the pilaster. Drill level top of pilaster with pilaster at wall, drill a 3/16" hole into not through the shoe, heel and the pilaster. Secure with 5/8" screw (FA-306).
- 6.9 Level the pilaster front and drill through the top panel bracket hole. Secure the panel with a 15/16" (FA-102) and 5/8" barrel. (FA-201). Drill and secure the remaining panel bracket hole(s).
- 6.10 Repeat steps 6.2 through 6.9 for each pilaster.

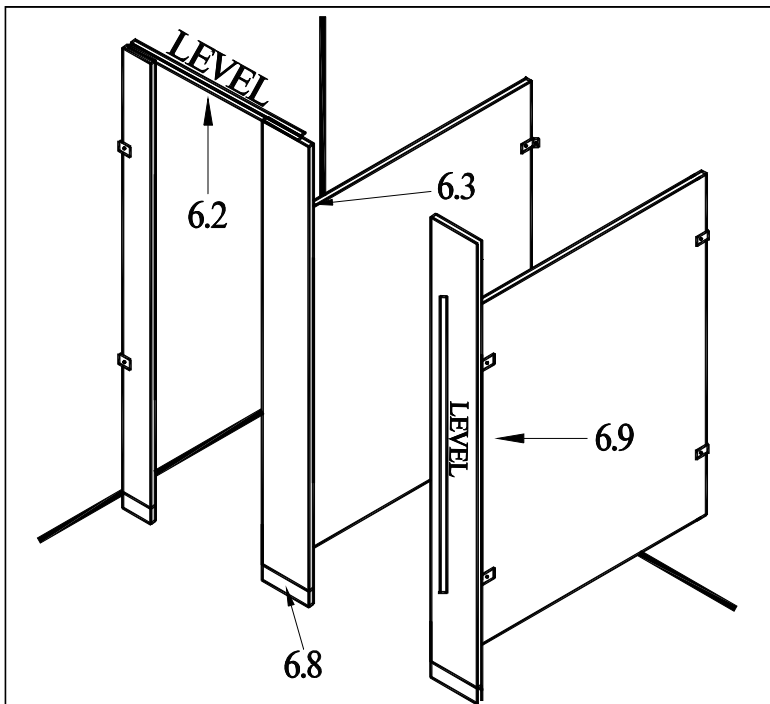

**FIGURE 6.1
PILASTER TO PANEL ATTACHMENT**

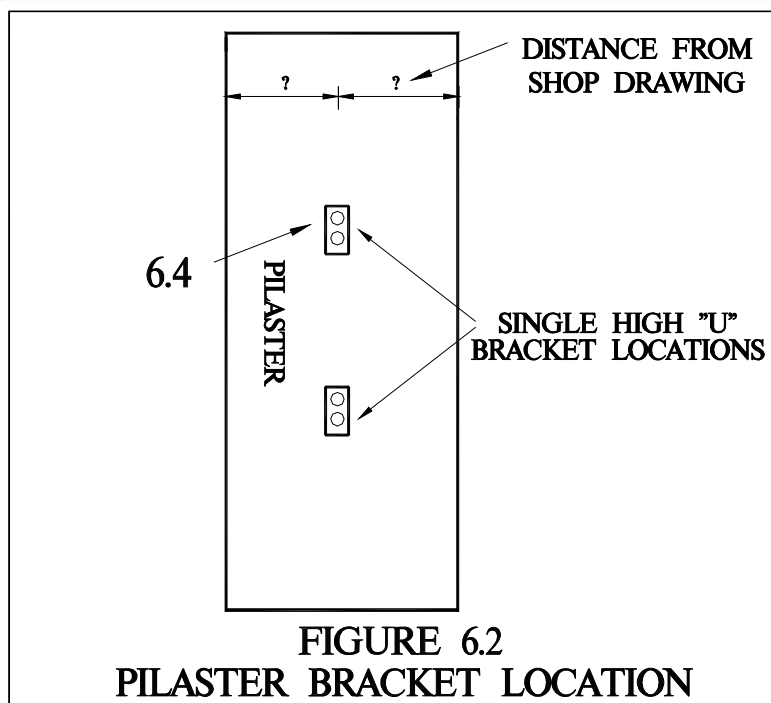

**FIGURE 6.2
PILASTER BRACKET LOCATION**

**SEE SHOP DRAWINGS FOR DISTANCE BETWEEN
PILASTERS BEFORE FASTENING PILASTERS TO FLOOR.**

7 INSTALL THE HEADRAIL

- 7.1 Measure and cut the front headrail to the appropriate length. For large openings, cut the headrail as long as possible with the cut in the center of a pilaster.
- 7.2 Lay the headrail on top of the pilasters and using the headrail bracket as a template attach to wall using the supplied fasteners.
- 7.3 Drill a 1/4" hole through the headrail bracket, headrail and the wall-pilaster. Secure with a 1-1/2" bolt (FA-110) and 5/8" barrel (FA-201).
- 7.4 For each pilaster, measure and mark the door opening width according to shop drawings. Drill a 1/4" hole through the headrail and the pilaster. Secure with a 1-3/16 bolt (FA-104) and 5/8" barrel (FA-201). See the notes to determine how many holes to drill.
- 7.5 For in-corner and free-standing configurations place an end-cap and a corner headrail bracket onto the end of the headrail. Drill a 1/4" hole through the headrail bracket, headrail and pilaster. Secure with a 1-1/2" bolt (FA-110) and 5/8" barrel (FA-201).
- 7.6 Measure from the top of the panel to the bottom of the corner headrail bracket.
- 7.7 Measure, mark and secure a headrail bracket on the wall at the height measured in step 7.6.
- 7.8 Measure from the back wall to the corner headrail bracket. Cut a piece of headrail to fit between the two brackets. Drill a 1/4" hole through the headrail and bracket and secure with 1-3/16" bolts (FA-104) and 5/8" barrels (FA-201).

Pilaster Size	# Bolts	Location
< 7"	1	Centered
8" – 13"	2	2" from each end
> 14"	3	2" from each end and one centered

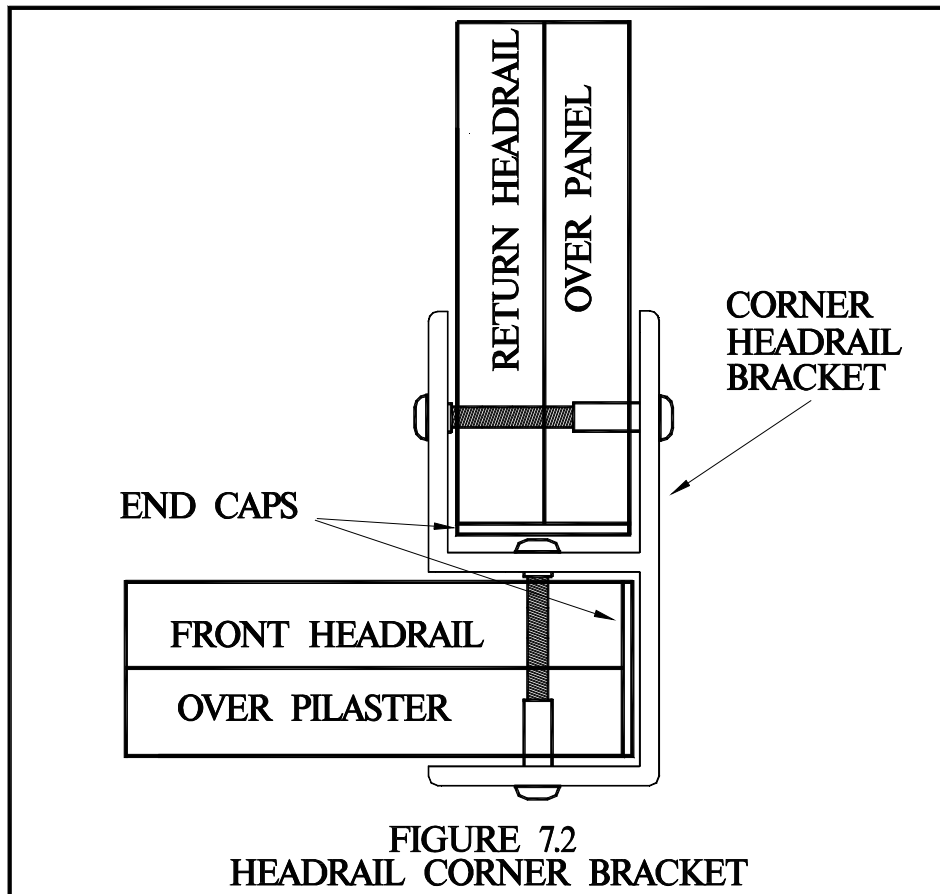
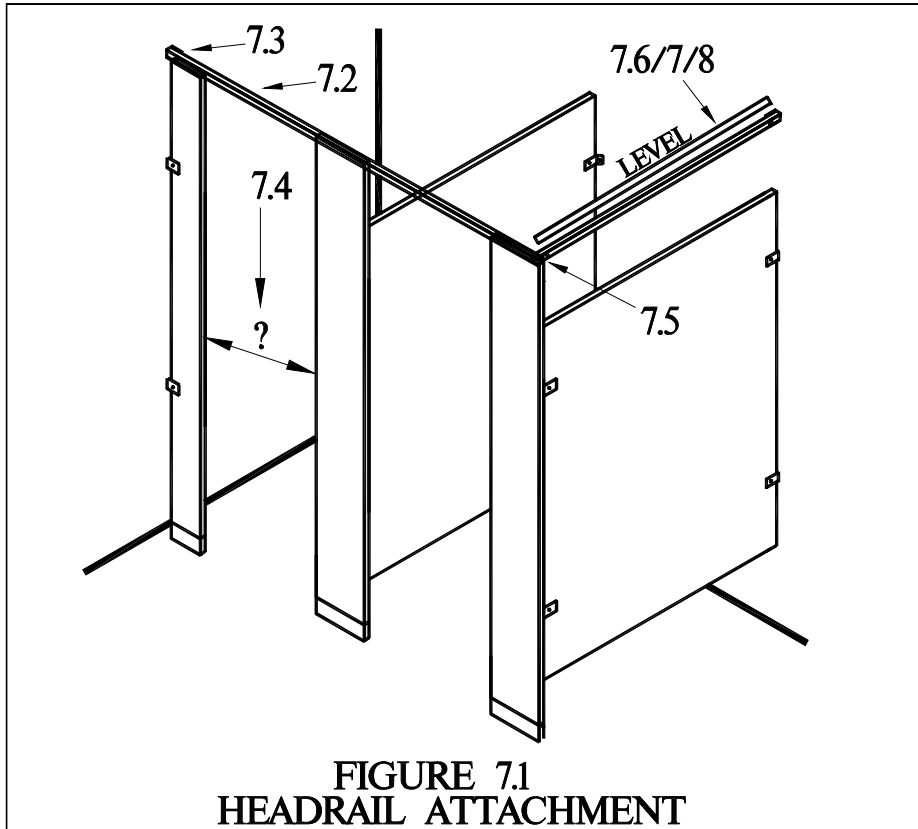

8 ATTACH THE DOORS

- 8.1 Secure part 1 of the top pilaster hinge onto the top of the pilaster with 1-3/16" bolts (FA-104) and 5/8" barrels (FA-201). (See fig. 1)
- 8.2 Secure part 2 of the bottom pilaster hinge onto the bottom of the pilaster with 1-3/16" bolts (FA-104) and 5/8" barrels (FA-201). (See fig. 1)
- 8.3 Insert the set pin into top of door.
- 8.4 Insert the hinge cam into the bottom of the door.
- 8.5 Attach the hinge pintle onto the bottom pilaster hinge.
- 8.6 Hang the door onto the pilaster and lower the top hinge pin into the top pilaster hinge.
- 8.7 Adjust the bottom hinge pintle for the closure required for your door operation.

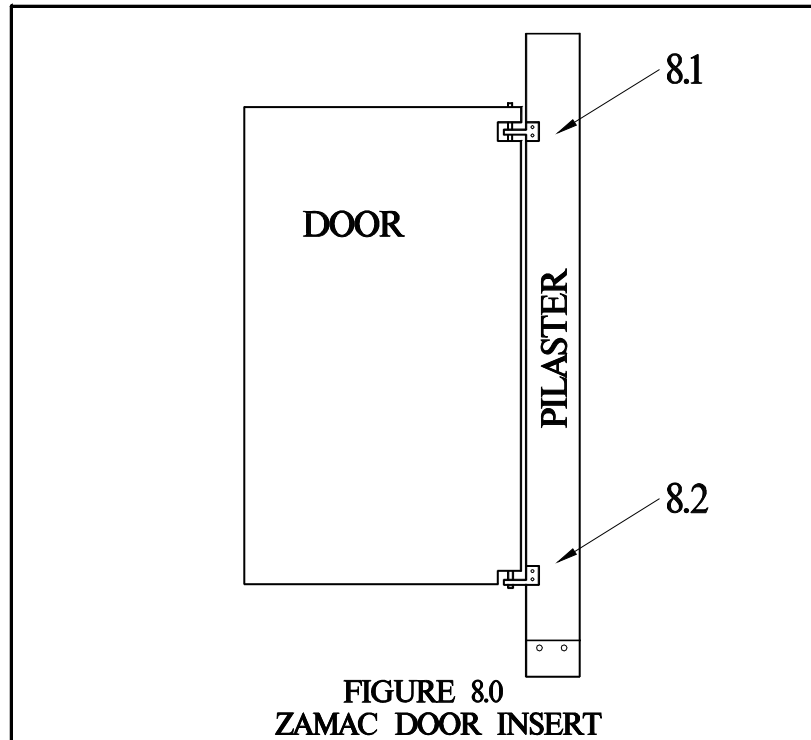

Notes:

- To increase or decrease the default door opening reposition the adjustable pin in the bottom hinge.

9 ATTACH THE DOOR HARDWARE

9.1 Mark the keeper position on the Pilasters.

9.1.1 For surface mounted latches, measure and mark the center of the keeper 41" above the finished floor.

9.1.2 For ADA doors see local codes for latch placement.

9.2 Using the keeper as a template, mark and drill 1/4" holes through the pilaster. Secure the keepers using 1-3/16" bolts (FA-102) and 5/8" barrels (FA-201).

9.3 Mount the door latch. Position the surface mounted latches on the inside of the door so the latch clears the keeper when the door opens. Using the latch as a template, mark and drill 1/4" holes through the door.

9.3.1 For inswing doors, secure the latch with 15/16" bolts (FA-102) and 5/8" barrels (FA-201).

9.3.2 For outswing doors secure the latch to the door pull with 1-1/2" bolts (FA-110).

9.4 Mount the coat hook / bumper

9.4.1 For inswing doors place the coat hook / bumper 4" from the top and outer edge. Mark and drill 1/8" holes in the door. Secure the coat hook / bumper to the inside of the door with 3/4" screws (FA-305).

9.4.2 For outswing doors center the coat hook 4" from the top. Mark and drill 1/4" holes in the door. Secure the coat hook with 3/4" screws (FA-305).



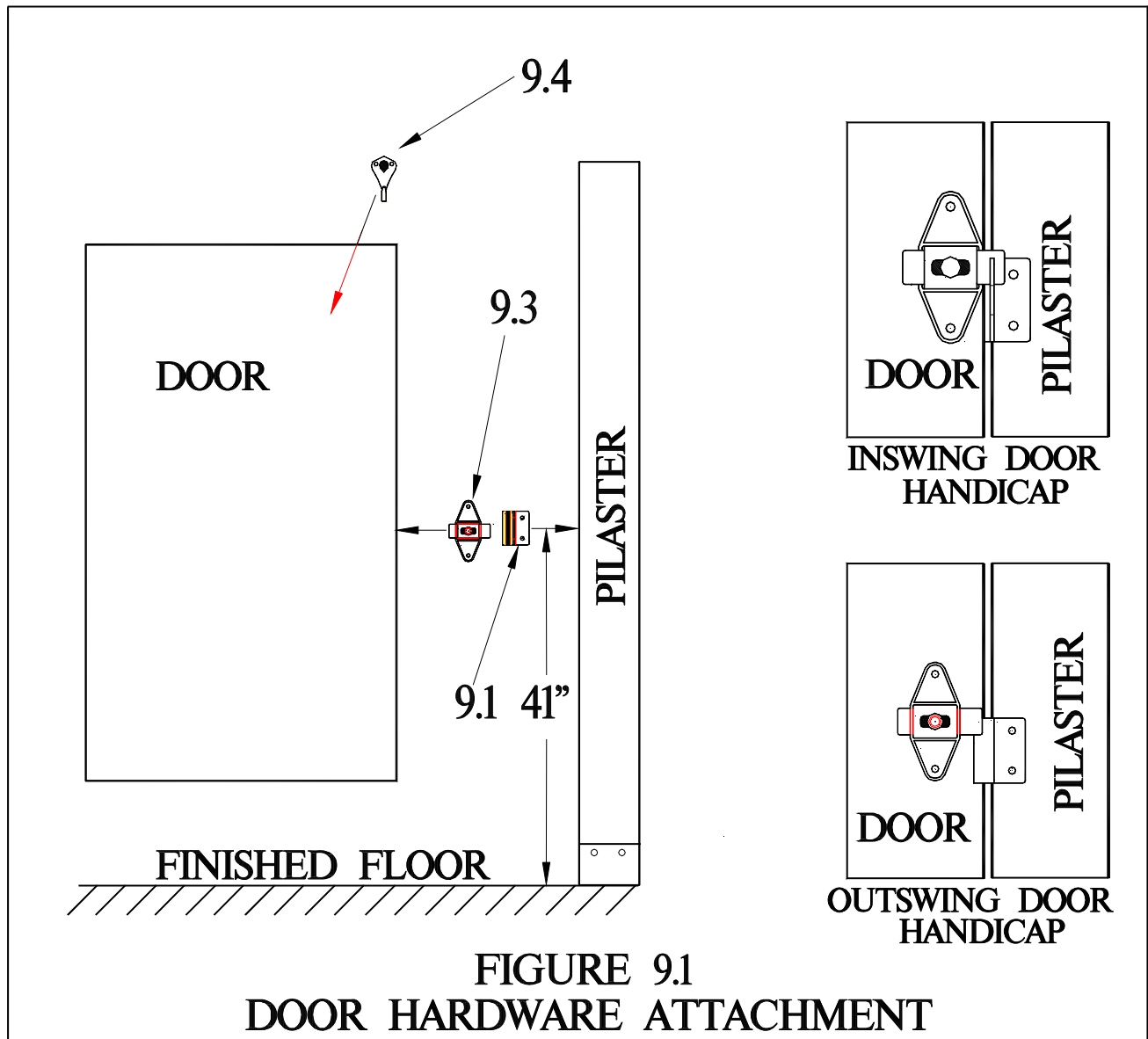





9.4.3 For ADA doors see local specifications for coat hook placement. (usually 48" from the finished floor)

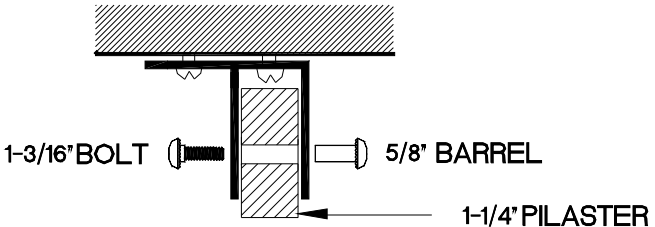
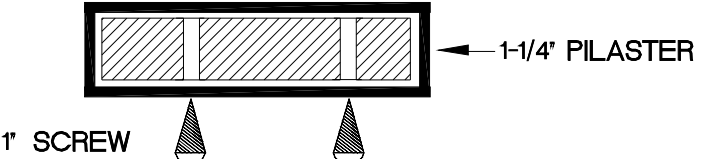

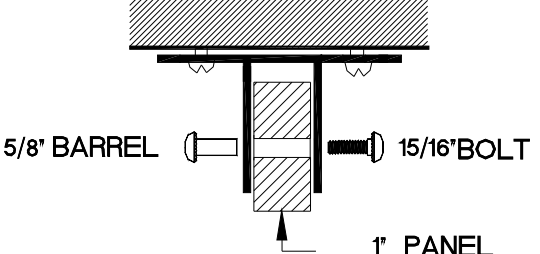
Notes

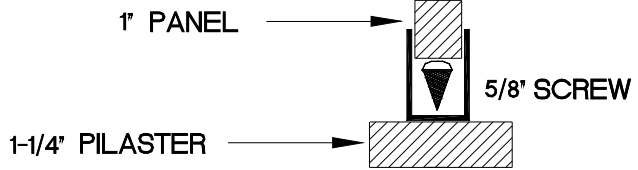
- For ADA and emergency access doors mount the latch near the top of the keeper so that when in the latched position the door can be lifted and opened.

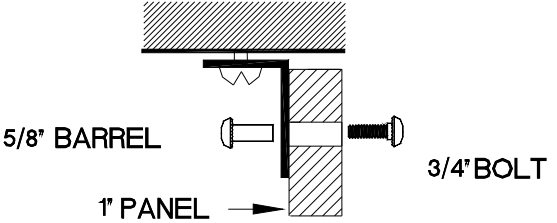
10 BOLT AND BARREL SIZES

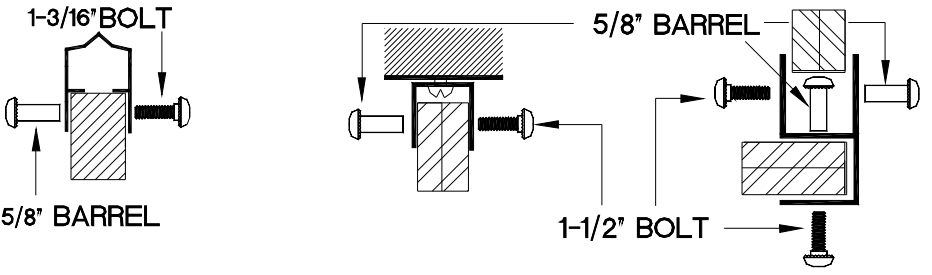
<p>PILASTER BRACKETS</p> 	 <p>1-3/16" BOLT</p> <p>5/8" BARREL</p> <p>1-1/4" PILASTER</p>
<p>SHOES</p>	 <p>1" SCREW</p> <p>1-1/4" PILASTER</p>
<p>PANEL BRACKETS</p> 	 <p>5/8" BARREL</p> <p>15/16" BOLT</p> <p>1" PANEL</p>
<p>PANEL TO PILASTER BRACKETS</p> 	 <p>1" PANEL</p> <p>5/8" SCREW</p> <p>1-1/4" PILASTER</p>
<p>ANGLE BRACKETS</p> 	 <p>5/8" BARREL</p> <p>3/4" BOLT</p> <p>1" PANEL</p>
<p>HEADRAIL BRACKETS</p> 	 <p>1-3/16" BOLT</p> <p>5/8" BARREL</p> <p>5/8" BARREL</p> <p>1-1/2" BOLT</p> <p>HR TO WALL BRACKET</p> <p>CORNER HR BRACKET</p>



PHONE: 1-866-820-3579

FAX: 1-866-317-2786

www.natpart.com

Copyright 2015